

**Front**

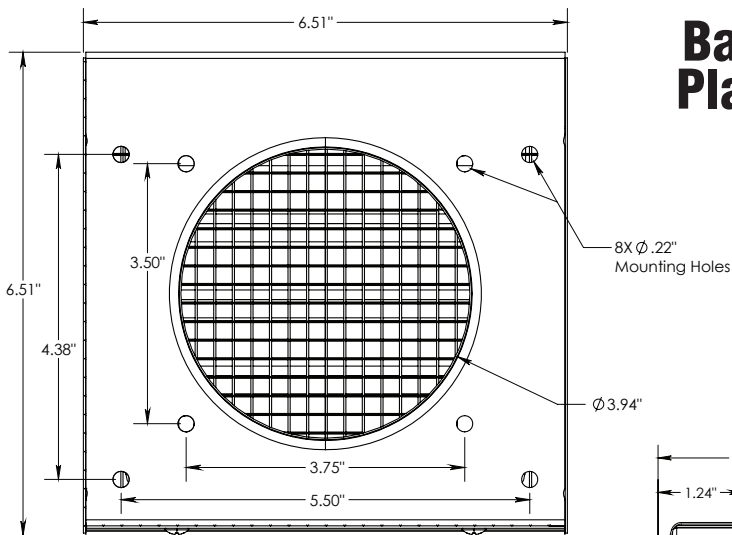

**Back Plate**

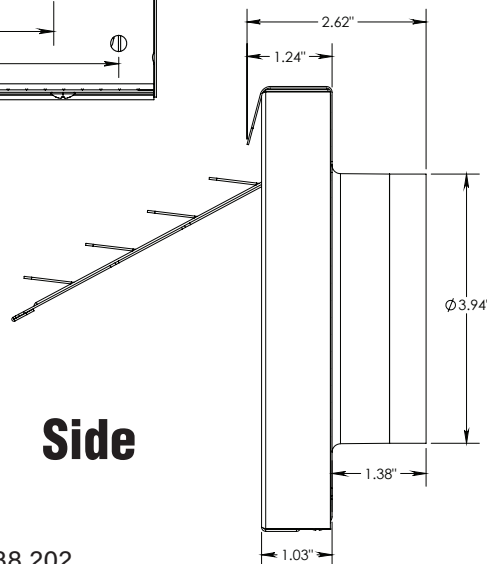

**Side**

Model Number	Color
FRV4W	White
FRV4T	Tan
FRV4B	Brown
FRV4K	Black

### Performance Data

**Product Use:**

- Intake Air Solution to Allow Fresh Air Into the Home to Help Improve Indoor Air Quality
- Complies w/ 2021 IMC Section 403.3 Outdoor Air Ventilation

**Materials:**

- Heavy Gauge Galvalume® Steel Housing
- Polyester TGIC Weather Resistant Powder Coating

**Carton Weight:**

FRV4: 12 lbs. (8/carton)

### General Information

**Benefits:**

- Allows Fresh Air Into the Living Space
- Creates a Clean Consistent Exterior Aesthetic
- Installs Easily to Function with HVAC, ERV & HRV Systems and Make-Up Air Units
- Complies with Code Requirements to Allow Fresh Air Into an Airtight, or Tight, Home
- Installs Easily in New and Existing Construction
- Sleek, Clean Lines Blend In or Stand Out as an Accent

**Features:**

- Tough, Durable Quality
- Deep Drawn Manufacturing Process
- Galvalume® & Powder Coated Steel Construction
- Stainless Steel Screen Helps Keep Wildlife Out
- Built-in Drip Edge Helps to Deter Rain Intrusion
- Collar Easily Connects to Standard 4-Inch Duct
- Integrated Secondary Back Plate with Wider Mounting Holes
- Eight Built-in Mounting Holes
- High Strength N52 Magnets Keep the Louvered Cover in Place
- Louvered Cover Lifts Up For Ease in Cleaning
- Stocked in 4 Colors: White, Tan, Brown and Black

### Manufactured By

InOvate® Technologies, Inc.  
 250 S. Central Blvd. Suite 207  
 Jupiter, FL 33458  
 Phone: (888) 443-7937  
 Fax: (561) 745-9723  
<https://freshvent.com>

